

TruLaser Weld

A winning  
connection



# Earn more with laser welding

So the range of services you offer already includes welding? Great! But now imagine you had a new welding system that could make parts 90 percent faster while cutting costs by 65 percent. We can show you how to achieve that. Read on to find out more.

**Automated laser welding catapults your sheet metal operations into a new league.**



**90%**  
time savings\*

**65%**  
cost savings\*

\* Compared to manual TIG welding. Figures based on the joining process for a mild steel cover with an aesthetically superior finish. See sample calculation on page 10.

<b>Create opportunities</b> _____	<b>4–5</b>	<b>LaserNetwork</b> _____	<b>17</b>
Exploit savings potential, identify growth potential		Boost your capacity	
<b>Laser welding pays off</b> _____	<b>6–7</b>	<b>Program faster, produce in parallel</b> _____	<b>18–19</b>
Unlimited possibilities		TruTops Weld, the navigation system for laser welding	
<b>The right method every time</b> _____	<b>8–9</b>	<b>Get up to speed with laser welding</b> _____	<b>20–21</b>
An overview of laser welding		Our production launch package	
<b>It pays off!</b> _____	<b>10</b>	<b>Your Smart Factory</b> _____	<b>22–23</b>
Cost comparison		Digital networking gives you great freedom	
<b>User feedback</b> _____	<b>11</b>	<b>TruServices. Your Partner in Performance</b> _____	<b>24–25</b>
What our customers think		We've got you covered	
<b>TruLaser Weld 5000</b> _____	<b>12–16</b>	<b>Passion is what drives us</b> _____	<b>26–27</b>
One system – countless benefits		Locking in competitive advantages	

The LED strip lighting in Terminal 1 at Frankfurt Airport was developed, laser welded, and fully assembled by the company LMT Leuchten + Metall Technik GmbH in Hilpoltstein, Germany.



# Create opportunities

Becoming an early adopter of laser welding gives you the chance to earn significantly more by letting you produce parts at a fraction of the cost. It also brings new contracts your way because you can work faster and offer more than your competitors. The fact is that joining offers more potential to save money than any other machining step in the sheet metal process chain!

## Provide outstanding quality

### High-quality seams

Are your customers looking for extremely stable or visually appealing seams? If so, laser welding is a great choice. It produces high-strength, tight, and aesthetically pleasing weld seams.



### Minimal distortion

The simple solution for high-precision welding. Laser welding has a lower heat input than arc welding, resulting in less distortion in the welding zone. That makes downstream processing easier.

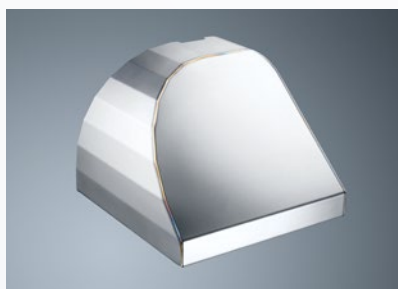

### Reproducible results

Automated laser welding offers consistent quality because robots remember every step perfectly.

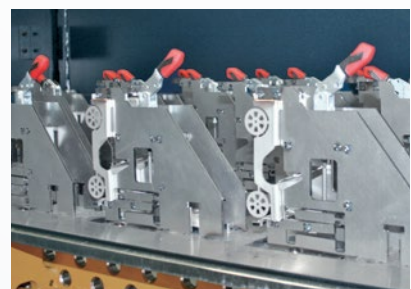

## Save time, cut costs

### Less finishing work

Lasers produce high-quality seams, often without requiring any finishing or grinding at all. Distortion is also kept to a minimum, eliminating the need for straightening. What's more, laser welding offers big savings on consumables such as grinding wheels.



Once you start using laser welding, you'll need far fewer grinding wheels.

### Huge time benefits

Laser welding is fast – and that makes it highly productive. It also involves fewer secondary operations, so you save an enormous amount of time.



See how much time you can save in this short video:  
[www.trumpf.info/eki40u](http://www.trumpf.info/eki40u)



The longer your current welding process takes and the more finishing work it involves, the faster an investment in laser welding will pay off.

## Embrace flexible production

### New seam geometries

Laser welding opens up a wide variety of new seam geometries, giving you more freedom when it comes to designing your parts.

Materials of different thicknesses

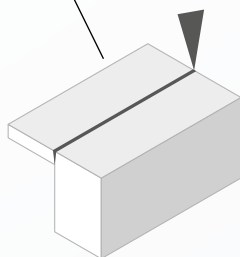

Lap seams

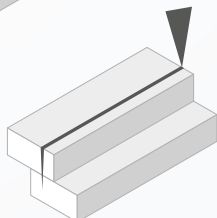

### Enhanced production capacity

A laser solution also helps you respond to big orders that come in unexpectedly – it handles series production orders faster and is immediately ready to process the next job.

Round geometries

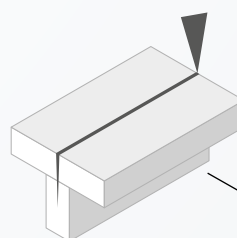

Concealed T-joints

# Laser welding pays off

Quality matters – and the benefits of laser welding are coming to the fore in many different industries. These include machine builders, kitchen and furniture makers, installation engineering, design engineering, and luminaire technology, as well as the food industry and electronics sector. Strong, deep, tight welds are crucial for applications such as water tanks. In contrast, counter segments require aesthetically pleasing visible weld seams with a smooth, rounded surface.

## Tank and equipment manufacturing, food technology

**Key requirements:**  
Tight welds

**Example:**  
**Stainless steel water tank**  
Create different seam geometries and tight seams to join sheets of different thicknesses (in this case, 1.5 and 3 mm).



## Mechanical and plant engineering

**Key requirements:**  
Low tolerances, high strength

**Example:**  
**Mild steel pipe-to-plate connection**  
Deep welding produces narrow, extremely strong seams in next to no time.



## Medical devices, furniture industry

**Key requirements:**  
Minimal distortion, visually appealing

**Example:**  
**Stainless steel counter segment**  
Heat conduction welding produces aesthetically pleasing visible welds.

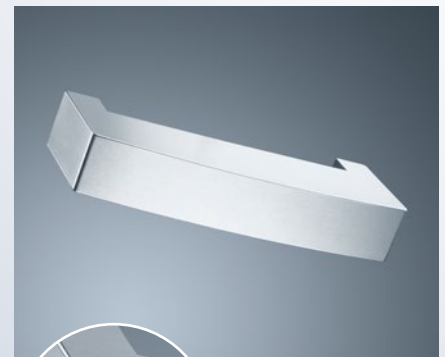

## Electrics and electronics

### Key requirements:

Minimal distortion, aesthetically pleasing

### Example:

#### Terminal box

Mild steel (bottom), stainless steel (middle), and aluminum (top): Laser welding produces high-quality results with a range of different materials.

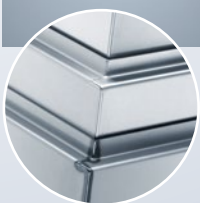
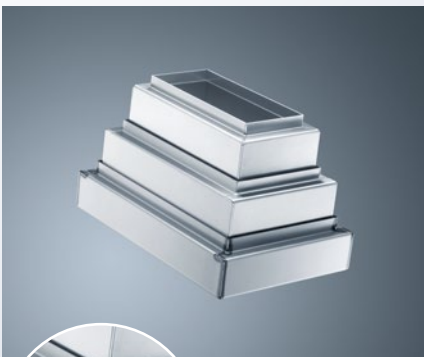

## Construction of machines and housings

### Key requirements:

Minimal distortion, aesthetically pleasing

### Example:

#### Mild steel cover

Heat conduction welding delivers beautifully rounded welds with virtually no distortion of the part, even with long weld seams.

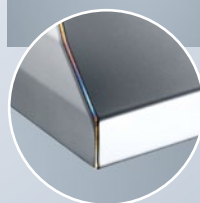
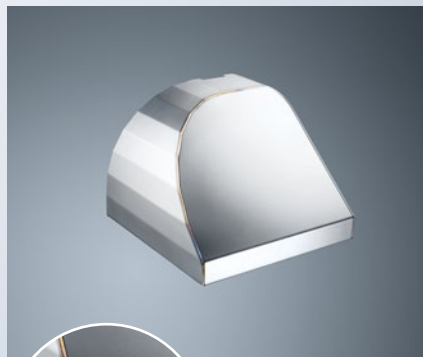

## Food technology, kitchen makers

### Key requirements:

Aesthetically pleasing, tight weld

### Example:

#### Stainless steel food service container

Heat conduction welding produces cosmetically superior seams – and TIG brushing is all you need to make them sparkle.

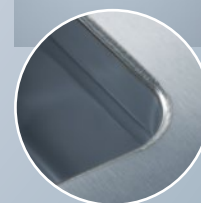

# The right method every time

Heat conduction welding, deep welding, or FusionLine – simply choose the best welding method for each part. And remember: You can use our laser welding system with all standard materials, such as mild steel, stainless steel, and aluminum.

## Laser welding is tremendously versatile

### Heat conduction welding

Aesthetically pleasing welds and maximum surface quality: The laser melts the workpieces along the joint, providing the perfect connection for thin-walled pieces. Heat conduction welding produces visually appealing visible seams with low distortion. In many cases, the parts require no further work.



### Deep welding

High welding speeds and strong seams: The laser heats the metal at the joint to such an extent that part of it vaporizes. As a result, the laser beam can penetrate deep into the material and connect even thick-walled pieces.

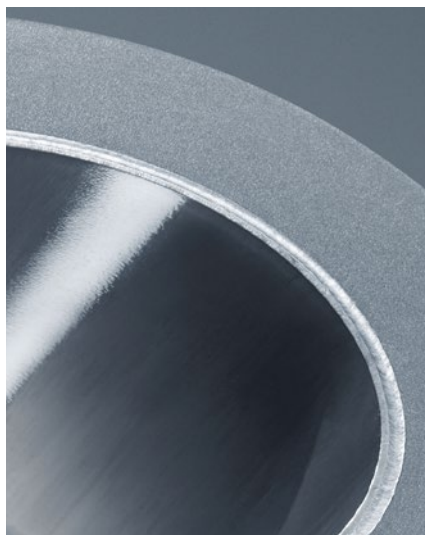

### FusionLine

We developed FusionLine to make it easier for companies to enter the realm of laser welding. It allows you to bridge gaps of up to 1 mm and efficiently laser-weld pieces together without having to optimize your parts portfolio for laser welding. Your machine can process more components, and the utilization rate increases.

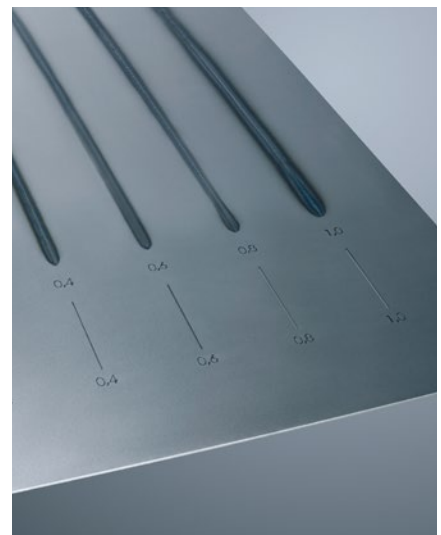





## FusionLine: Tolerant laser welding

### Higher utilization rate

You can produce parts true to the drawings and more kinds of parts because there is less or even no need to redesign.

### Less demanding

FusionLine is forgiving when it comes to slight inaccuracies that may arise during bending, for example. It allows you to bridge gaps of up to 1 mm.

### Less finishing work

The quality of the weld is significantly higher than arc welding, even though it isn't quite as good as a pure laser weld.

### Fully flexible

Use FusionLine, heat conduction welding and deep welding on the same part without retooling.



Mild steel terminal box (from bottom to top): unwelded, manual MAG weld, FusionLine weld, and laser weld after redesigning for laser processing.

### Comparison of different welding methods

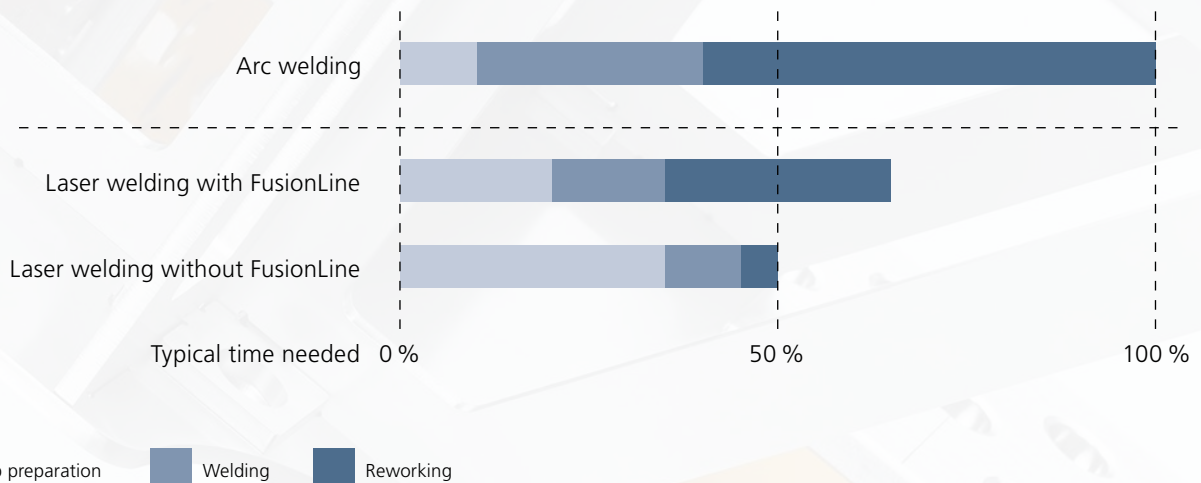

# It pays off!

The figures below are based on the example of a mild steel cover requiring an aesthetically superior finish. By using automated laser welding, you can join the pieces more than 90 percent faster and cut the cost per part by 65 percent. Since joining makes up the lion's share of part costs, this results in 50 percent cost savings for the overall sheet metal process chain.

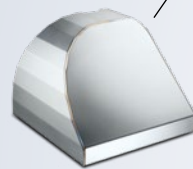

500 pieces a year (10x batches of 50)  
1.5 mm mild steel 122 cm weld seam

## Manual TIG welding

## Laser welding

Hourly cost*	60 €	149 €
Fixture costs	0 €	4000 €
Programming time	0 min	240 min
Set-up time per batch	5 min	15 min
Welding time per part	45 min	2 min
Handling time per part	2 min	2 min
Rework per part	10 min	0 min

<b>Total time*</b>	<b>476 h</b>	<b>40 h</b>	← Savings of over 90%
<b>Total cost*</b>	<b>28550 €</b>	<b>9935 €</b>	← Savings of 65%
<b>Cost per part*</b>	<b>57.10 €</b>	<b>19.87 €</b>	



Utilize 50% of your system's capacity with these kinds of parts in one shift, and it will pay off within approx. two years.

\* These figures are based on average figures typical for Germany.

# User feedback

“The only thing I regret is that we didn’t start earlier.”

Werner Neumann, CEO of CBV Blechbearbeitung GmbH

Customers such as Mr. Neumann are already enjoying the benefits of laser welding in practice. The company CBV Blechbearbeitung GmbH is a contract manufacturer based in Laasdorf, Germany, that serves a wide range of industries. Werner Neumann’s customers rely on his expertise right from the part design phase. One example is an aluminum U-shaped profile with close-fit areas, holes, and notches, which in the past was milled from solid material. “Now we cut the parts with the laser and deep-weld them at the base. Thanks to the low degree of thermal input, there is no distortion. We brush over the seams and thus save 95 percent of our previous costs. It goes without saying that the customer is thoroughly satisfied,” Neumann reports.



“The demand for laser welding took off so quickly that we decided to invest in a second laser welding cell just one year later.”

Vaclav Kriz, Production Manager at Sinop



Sinop produces a broad range of cooling and beverage dispensing equipment in the Czech Republic. The company began working with laser cutting in 2011 and added a laser welding cell soon after. They chose an economical way to get into laser welding by using one laser to operate both systems in a laser network. Their machine operators were able to build up key experience with the new technology without having to make a huge investment.



# TruLaser Weld 5000



01

## Enjoy flexible laser welding

with different welding processes in one system

02

## Fix parts in place easily

with the modular clamping system

03

## Make your job easier

with the status monitor and other features

### One system – countless benefits

With its robot, laser, processing optics, safety enclosure, and positioning units, the TruLaser Weld 5000 offers a turnkey solution for automated laser welding. This is a highly versatile machine that can be tailored to your exact requirements.



06

### Reliable joining

with functions such as the optimized TeachLine

05

### Load it your way

with variable configurations

04

### Improve accessibility

with a rotary module for shield gas guidance

01

## Enjoy flexible laser welding

with different welding processes in one system

Offering heat conduction welding, deep welding, and FusionLine, your TruLaser Weld 5000 laser welding cell boasts an impressive range of welding options. Exploit this potential to significantly reduce your part costs. Using the welding program, you simply set the process, the amount of shielding gas, and strength of the compressed-air crossjet at the optics.



You simply set the right process using the welding program.

02

## Fix parts in place easily

with the modular clamping system

When you first start laser welding, designing clamping fixtures can be a challenge. This modular clamping system provides the help you need, enabling you to use a single fixture to hold parts of different shapes and sizes firmly in place. You can adjust the fixture to accommodate your workpiece in no time at all.

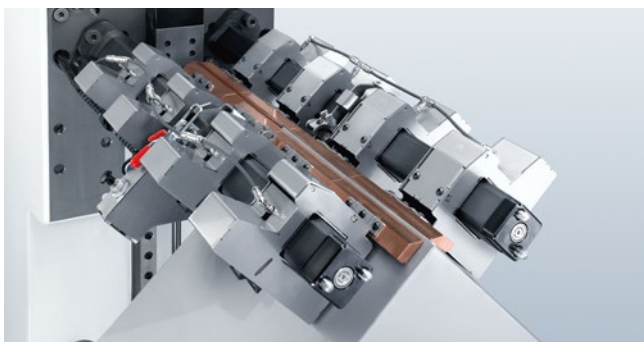

Fabricate 90° corner and butt joints.

03

## Make your job easier

with the status monitor and other features

There are plenty of features designed to make your TruLaser Weld 5000 especially easy to use, including a swiveling control console. You can also install an additional status monitor on the machine to keep track of the current job from a distance. Parts can be programmed directly at the robot, or with TruTops Weld in the office. Existing programs can be selected quickly from the production screen on the control unit. Large windows offer a good view of the work area, and the automatic door provides fast access.



User-friendly features of the TruLaser Weld 5000 include a swiveling control panel and an additional status monitor.

04

## Improve accessibility

with a rotary module for shield gas guidance

The shielding gas nozzle can be moved a full 360° around the processing optics. This reduces the need for the robot to realign itself, reducing the time and effort required for clamping and programming. The rotary module makes your parts more accessible, boosting welding speed considerably.

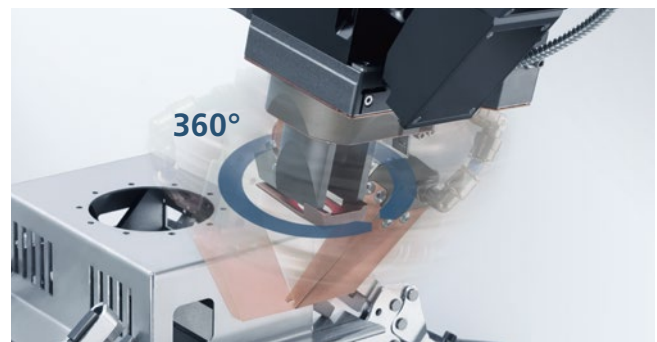

The rotary module for shield gas guidance allows users to rotate the nozzle 360° around the processing optics.



05

## Load it your way

with variable configurations

Choose the part positioner in accordance to your needs. Available options are a rotate and tilt positioner, a rotary table, a rotational changer, and a turnover positioner for extra large parts.

### Available part positioners



The rotate-and-tilt positioner enables you to weld even hard-to-access parts in a single clamping setup.



The rotary table can be set up outside the laser cell while welding is taking place inside, boosting your system's efficiency.



An automatic rotational changer is also available for applications that require fast, fully automated positioner rotation.

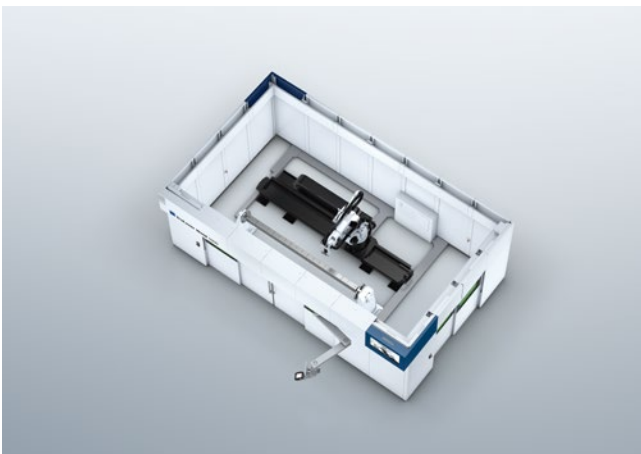

XXL parts are handled by the turnover positioner: the robot moves along a linear axis for further reach.



06

## Reliable joining

with functions such as the optimized TeachLine

A magnetic coupling provides protection in the event of a collision, and the sturdy robot ensures reliable processes. Four LEDs on the protective glass monitoring unit indicate the degree of contamination, which saves on visual inspections.

The TeachLine sensor system reduces the time and effort required for reteaching. It detects when the actual position differs from the required position and automatically corrects the program. The second line laser enables you to take measurements independently of the direction. A particular highlight is the optimized visualization of the welding process, which means you can already check the seam during welding.

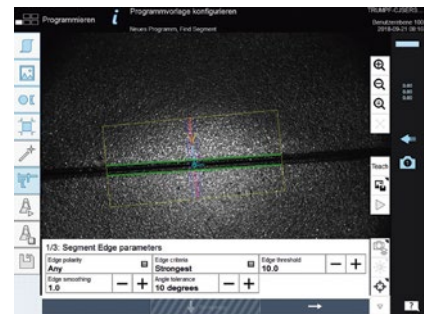

Reduce the need for reteaching: Save time with TeachLine.

Technical specifications									
<b>Handling system</b>									
Type	High-accuracy robot								
No. of axes	6								
Repeat accuracy	mm	± 0.05							
<b>Welding cabin</b>									
Available booth dimensions	mm	4800 x 4800	4800 x 5950	5950 x 4800	5950 x 5950	7100 x 4800	8250 x 4800	Height 3200	
<b>Max. work area</b>									
Rotate-and-tilt positioner <sup>1)</sup>	mm	2000 x 1000 x 700							
Rotary table	mm	1600 x 800 x 1200							
Rotational changer	mm	2000 x 1000 x 1100							
Turnover positioner with robot on linear axis <sup>1)</sup>	mm	4000 x 1500 x 1000							
<b>Max. load</b>									
Rotate-and-tilt positioner	kg	400							
Rotary table (each side)	kg	250							
Rotational changer (each side)	kg	750							
Turnover positioner with robot on linear axis	kg	1000							
<b>Laser</b>									
Available lasers	TruDisk 2000, 3001, 3002, 4001, 4002, 5001, 5002, 6001, 6002, 8001, 8002								
<b>Max. sheet thickness, Heat conduction welding<sup>2)</sup></b>									
Power output	W	2000		3000			4000		
Stainless steel	mm	1.5		2.5			3		
Mild steel	mm	1.5		2.5			3		
Aluminum	mm	1.0		2.0			2.5		
<b>Max. weld depth, deep welding<sup>2)</sup></b>									
Power output	W	2000	3000	4000	5000	6000	8000		
Stainless steel	mm	3	5	7	8	10	11		
Mild steel	mm	3	5	7	8	10	11		
Aluminum	mm	2	3	4	5	6	7		

<sup>1)</sup> Typical max. values; other width/depth/height ratios are also available.

<sup>2)</sup> Standard values: Exact maximum values are dependent on, for example, material properties.

Subject to alteration. Only specifications in our offer and order confirmation are binding.

# LaserNetwork

Are you keen to produce parts using the latest technology but reluctant to make a major capital investment? Do you already have a laser source that occasionally sits idle? Then it's time to boost your capacity by using a single laser for multiple machines in the TRUMPF LaserNetwork. This is an economical way to get started with laser welding. It makes optimum use of your laser source and keeps you flexible for whatever the future may hold.



## Take advantage of the growth potential

Enter growth markets such as laser welding – complete initial orders and expand your expertise and customer base.

## Halve costs

If a laser supplies two machines, your investment costs for the beam source are halved.

## Expand the portfolio

Provide your customers with more services – integrate new technologies into your production that harness a joint beam source.

## Use your laser to capacity

Supply multiple machines with one beam source and fully utilize the capacity of your laser.



Besides the TruLaser Weld 5000 for the robotic welding of sheet metal, you can also find cartesian solutions for the 3D processing of metals. You can even combine cutting and welding applications with them. Please feel free to contact us; we are most happy to advise.



# Program faster, produce in parallel

The navigation system in your car guides you reliably to your destination. Wouldn't it be great to also have a navigation system for laser welding? Look no further than the TruTops Weld programming system. You can program offline on the computer while production continues on your machine. Adapt the program at the machine simply using TeachLine or by reteaching to the actual position of the component.

## The benefits for you: From the CAD model to the welding program in four steps

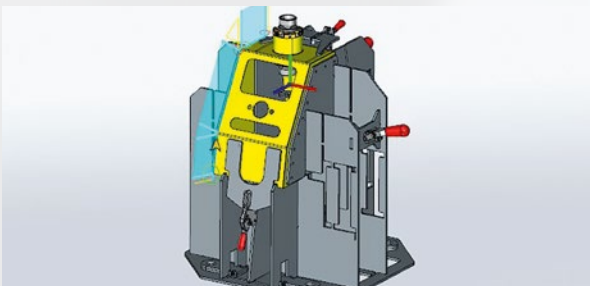

### 1. What do you want to weld?

Load your component into TruTops Weld and mark the seams to be welded.

The software is easy to use and packed full of TRUMPF expertise, such as welding parameters and processing angles. You select only the necessary values, and the program is created automatically – offline on the computer, reducing your nonproductive time.

**> You program faster and reduce nonproductive time**

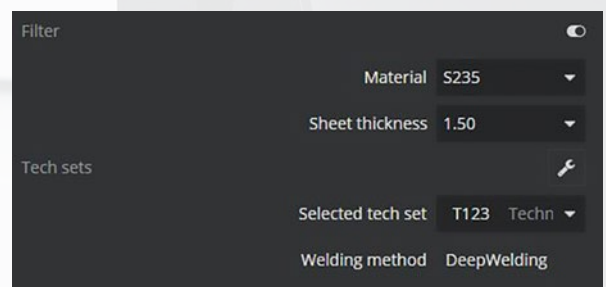

### 2. How do you want to weld?

Select the welding parameters that fit your material and desired result for heat conduction welding, deep penetration welding, or FusionLine.

Programming is performed on the computer in the office, and operation carried out at the machine – one person can be responsible for this, or a team of operators and programmers.

**> Deploy staff in a targeted way**

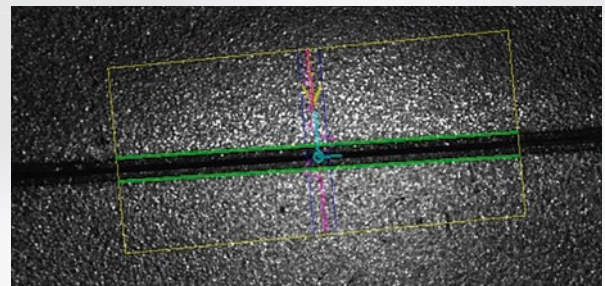
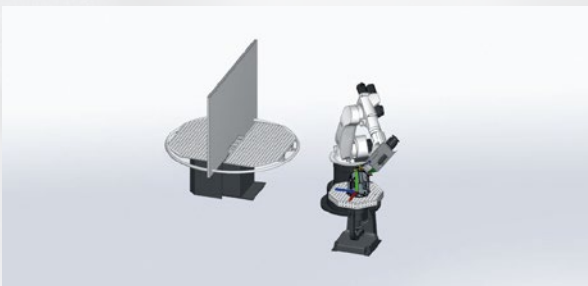

### 3. Where do you want to weld?

Position the component virtually on the desired component positioner. Due to TruTops Weld, you can quickly detect possible collisions and adapt the program. The software makes suggestions and makes it easier to check the accessibility of complex components.

### 4. The desired result fast

Load the program created offline onto your precisely calibrated TruLaser Weld 5000. TeachLine detects the actual position of your component and automatically adapts your program. This reduces the time for retooling substantially. Alternatively, you can retool the program conventionally.

➤ You simplify complex tasks

➤ You can even produce small quantities profitably





# Get up to speed with laser welding

The TRUMPF production launch package ensures you make the most productive use of your laser welding system right from the start. We provide step-by-step support until your part is run in on your new machine and you begin producing your first batch of laser-welded parts. Alternatively, select precisely the support that you need – whether for specific aspects or the complete package, and always customized to your requirements.



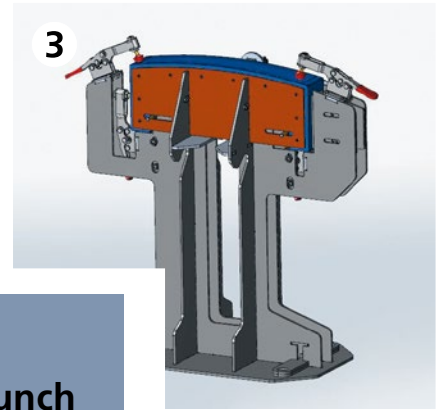

Select the entire production launch package or book individual modules.

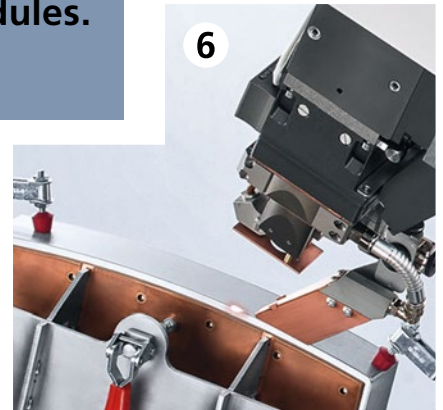
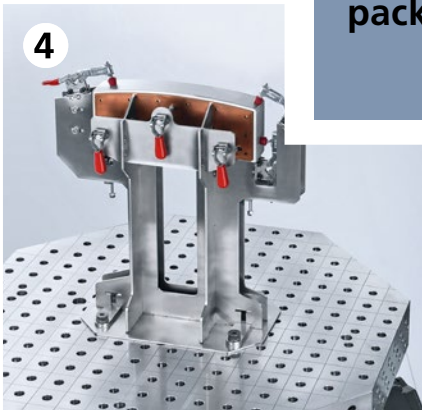

### 1. Select part

TRUMPF will help you choose a part for production ramp-up.

### 2. Attend workshop

TRUMPF will run a workshop at its offices or at your company to teach you the basics of laser welding and fixture design. You can then apply what you have learned to the part you have chosen.

### 3. Design part

TRUMPF design experts will support you in the laser-oriented design of your component, and when designing your fixture.

### 4. Build fixture

It is best if you produce the fixtures yourself on your own 2D laser processing machine, and adjust them to your component. If there is no capacity, order your fixture from TRUMPF.

### 5. Run in component

A TRUMPF application consultant runs in the component together with you, creates the program, and optimizes the welding parameters. Through practical learning using an actual part, you learn about the key rules for laser welding.

### 6. Begin productive laser welding

Once your machine is up and running, it takes just the press of a button to manufacture your first part on your new TruLaser Weld 5000. You're off to a highly productive start, and our training has given you the skills you need to quickly move on to welding other parts.



# TruConnect. Your Smart Factory



# 80%

Indirect processes make up 80% of your production time – this is where the greatest potential for saving lies.



Discover what potential networked production offers for you with two example scenarios: [www.trumpf.com/s/smart-factory](http://www.trumpf.com/s/smart-factory)





Gain more freedom with networking: You see more, know more, and get the best out of your production system. With TruConnect, the synonym for Industry 4.0 at TRUMPF, you can design your Smart Factory step by step. The pragmatic solutions from TRUMPF support you on your path towards networked production, helping you to make your entire process more transparent, more flexible, and above all more cost-effective.

### For companies big and small: From the simple product solution right through to fully networked production

- **Start simply** with machines that are equipped for networking as standard.
- **Customize step by step** with automated machines or autonomous processing cells embedded in a production solution.
- **Enjoy full networking** with a continuous production solution, from order to delivery.

### Smart functions and Industry 4.0

Due to the universal Central Link data interface, your TruLaser Weld machine is ready for Industry 4.0 and can be connected to other systems via OPC UA.

With the Visual Online Support from TRUMPF, you can share image, sound, and video files with our Technical Service department via app. This increases the availability of your machine, and saves time and costs.



The Central Link data interface is the basis for increased transparency and improved production.



Visual Online Support: Communicate quickly, easily, and securely with the Technical Service department via app, and ensure you have maximum machine availability.



You can find **further information** on networked production here:  
[www.trumpf.com/s/smart-factory](http://www.trumpf.com/s/smart-factory)



# TruServices. Your Partner in Performance

To ensure your future success, you need services that definitely put you ahead of the pack for the long term. Whether that means creating the best conditions for successful production, or using your TRUMPF laser welding system perfectly to adapt to changes with flexibility – together we'll find ways to sustainably maximize your value creation. As a reliable partner, we will provide you with comprehensive solutions and service packages for your requirements – so that you can produce cost-effectively and at a constantly high level.

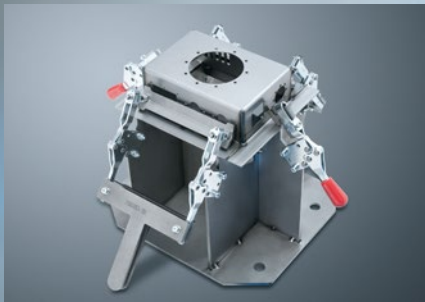

## Training

**EMPOWER:** Use the benefits of laser welding for the effective designing of your components. In the workshops on laser welding and fixture design, learn the design principles of cost-effective welding fixtures made from sheet metal. With the programming courses for operators, you are perfectly equipped for future tasks.

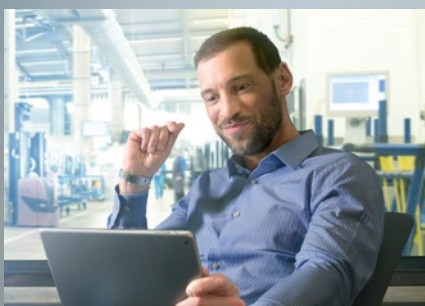

## Service Agreements

**SUPPORT:** Sit back and relax. Even the smallest package pays off – with a service agreement, your TruLaser Weld remains optimally available and in top condition. Regular maintenance saves you time and money. Unforeseen expenditure is replaced by calculated expenses.



## Application consultation

**IMPROVE:** Get the best out of your machine from the very beginning. A TRUMPF application engineer can provide you with on-site support and determine the optimal welding parameters for your component in the laser welding program. The advantage is that your parts are thereby optimally run-in on the machine.





Financing

Training

Pre-owned machines

Technical Service

Tools

Genuine Parts

Design and programming software

Process optimization

Monitoring & Analysis

Product enhancements

Value Packages

Service Agreements



**Find out** about our comprehensive complete package of helpful services:  
[www.trumpf.com/s/services](http://www.trumpf.com/s/services)



# Working in perfect harmony for your success

From the machine to the laser and the optical system to the technology data – intelligent machine functions are based on the interaction of different components. This is why we focus on consistent solutions, right up to the finest detail – the best basis for your success.



**You have an optimally available production system.**

## TruServices

We are always there for you with our comprehensive range of services and a global service network.

## Software

With software solutions from TRUMPF, you can optimize your production process. The TruTops Weld programming system is optimally designed for your machine.

## Automation

Different component positioners are available for your TruLaser Weld machine – for example, the automatic rotational changer for loading and unloading parallel to production.

## Process expertise

Every machine contains up-to-date technology data for laser welding checked by TRUMPF – so you can get started right away.

## Optical system

We develop lasers, laser guide cables, and welding heads adapted to the relevant requirements. The advantage for you – you can use the power of the tool laser to the fullest.

## Machine

TruLaser Weld 5000 is developed and produced by TRUMPF – you are provided with a robust solution for your day-to-day industrial applications.

# Passion is what drives us

Whether it's production and manufacturing technology, laser technology, or material processing – we develop highly innovative products and services which are suitable for industry and absolutely reliable. We put everything we've got into giving you a compelling and competitive edge: expertise, experience, and a lot of passion.



Visit us on YouTube:  
[www.youtube.com/TRUMPFtube](http://www.youtube.com/TRUMPFtube)

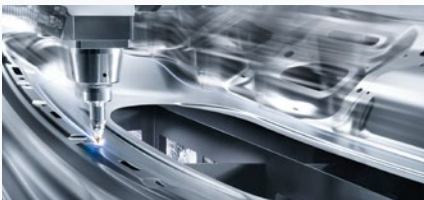

## Lasers for manufacturing technology

Whether on a macro-, micro-, or nanolevel: We have the right laser and the right technology to produce innovatively and cost-efficiently in every industrial application. Beyond the technology itself, we support you with system solutions, application knowledge, and consulting.



## Power supplies for high-tech processes

From semiconductor manufacturing to solar cell production: With our RF and MF generators, the current for induction heating, plasma and laser excitation is given a defined frequency and power – with high reliability and repeatability.



## Machine tools for flexible sheet metal and tube processing

Whether it's laser cutting, punching, bending, or laser welding: We offer tailor-made machines and automation solutions, including consulting, software, and services, for all processes in flexible sheet metal processing – so you can reliably manufacture your products to exacting quality standards.



## Industry 4.0

The TruConnect range of solutions links man and machine with information. It covers all steps in the production process – from the offer right through to the shipping of your parts.

TRUMPF is certified to ISO 9001  
(Find out more: [www.trumpf.com/s/quality](http://www.trumpf.com/s/quality))



TRUMPF Werkzeugmaschinen GmbH + Co. KG  
[www.trumpf.com](http://www.trumpf.com)